

# SUNPOLE C

CONNECTED AUTONOMOUS LIGHTING SOLUTION



ECLATEC



Residential area



Park

# SUNPOLE C

Developed by France's leading public lighting company, SUNPOLE C is a reliable and efficient solar solution, **designed and manufactured in France**. It features:

- a **high-performance LED luminaire**, suitable for all applications thanks to a wide range of photometric distributions and colour temperatures, solutions **Tunable White** to protect the environment,
- some **SMART features** with pre-wiring for **ZD4i**, Smart-Ready on top and/or underneath, night-time dimming, **detection** of presence, dynamic lighting and **remote management** to meet all uses,
- a **French LITHIUM battery** that is efficient, secure and long-lasting,
- a photovoltaic panel **monocrystalline** with high efficiency,
- a **personalised study** conducted by ECLATEC, making it possible to select the location, define the optimum photometry compliant with standards, as well as the energy sizing to maximise continuity of service.



Industrial area



- ✓ **Effective**
  - ECLATEC LED solutions
- ✓ **Smart**
  - connected autonomous lighting
- ✓ **Aesthetics**
  - ECLATEC LED luminaires
- ✓ **Respect for biodiversity**
  - Tunable White solutions
- ✓ **Plug & play**
  - Settings and functional tests carried out by ECLATEC

## SUNPOLE C: STAND-ALONE SOLUTIONS FOR EVERY APPLICATION

The **Sunpole C** range stands out for its **adaptability** to the varied requirements of urban and rural environments.

Sunpole C can be adapted to all your applications thanks to its **modularity**:

- ▶ **Various sizes:** different heights available to perfectly adapt to your needs
- ▶ **Several colours available** to enhance your landscapes or blend in with your street furniture.
- ▶ **Tailored combinations:** compatible with multiple luminaires to meet the specific needs of every project
- ▶ **STRIUM finish available**

Every detail has been thought through to make sure your installation meets your needs while providing optimum lighting performance.

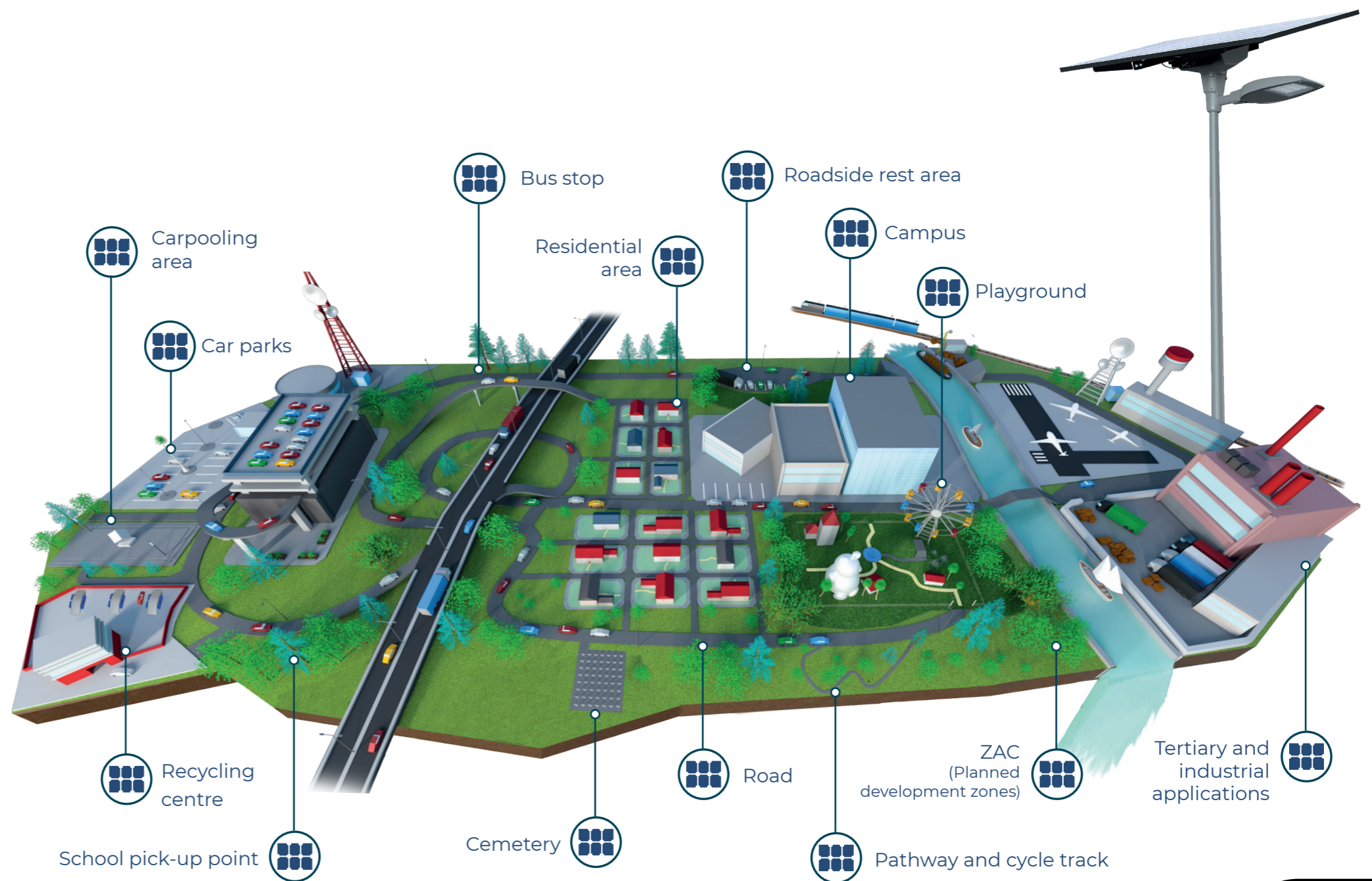

# SUNPOLE C

## Elegant, functional architecture

### Removable cassette

- Battery compartment
- Electronic compartment
- Easy access & maintenance
- Locking screws
- IP 66 ingress protection

### Photovoltaic panel

- 440 Wc
- Rotatable through 360°
- Fixed 20° tilt

Adjustable 360°

### Luminaires from the GHM ECLATEC range

#### Tweet Neo S1

- Injected aluminium casting
- IK 10, IP 66
- Side mount
- Pre-tilted at 2°
- In accordance with the "Limitation of light pollution" decree of 27 December 2018

### High-performance LED with Tunable White solutions

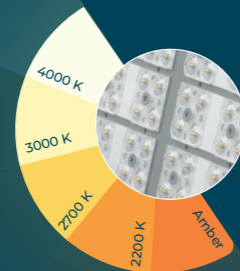

### PHOTOMETRIC distributions ECLATEC \*

- Optimised and adapted to the different uses (illuminance, luminance, projection, asymmetrical, symmetrical...)

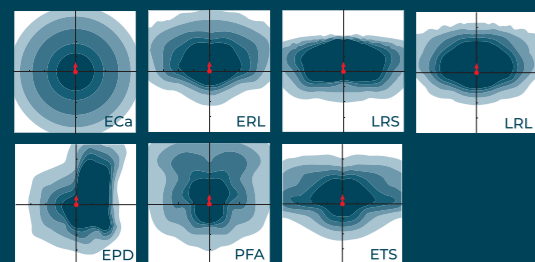

### Smart

- Smart-Ready on top and/or underneath **ZDi**
- Night-time dimming at set times and/or according to the ephemerides
- Detections
- Dynamic lighting
- Remote management



### Delivery & installation

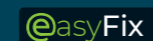

- Factory tested and programmed
- Optimised packaging
- User-friendly assembly
- Quick commissioning

### Overall configurations

Pole cylindrical-conical

Pole tilting

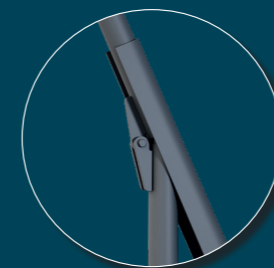
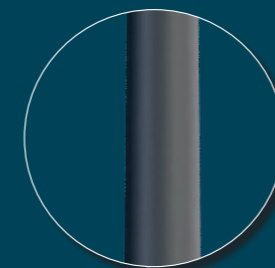

STRIUM customisation (optional)

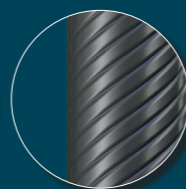
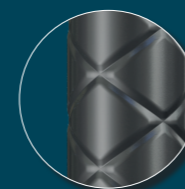

Capitan

Hélix



\* Partial list of distributions

# SUNPOLE C

Design: ECLATEC

## Technical specifications



### TWEET NEO S1 LUMINAIRE

#### DESCRIPTION

<b>Luminaire body</b>	Injected aluminium casting
<b>Bowl</b>	Screen-printed polycarbonate
<b>Finish</b>	Polyester powder coating, choice of colours
<b>Shock resistance</b>	IK 10
<b>Leak tightness</b>	Leak tightness level IP 66 as per the EN 60 529 standard Extruded silicone seal Anchored cable gland Luminaire ventilation with activated carbon filter
<b>Dimensions (L x W x H)</b>	572 x 320 x 92 mm
<b>Weight</b>	4 kg
<b>SCx</b>	0.05 m <sup>2</sup>
<b>Electrical class</b>	Class III
<b>Maintenance</b>	Access to the LED sources and smart components after removing the bowl held by 4 captive screws (safety cable)

#### SOURCES & PHOTOMETRIC DISTRIBUTIONS

<b>Sources</b>	Strips BLS 12
<b>Colour temperatures</b>	Amber*, 2200 K, 2700 K, 3000 K, 4000 K
<b>Lenses and distributions</b>	<b>QUADRALENS</b> ERS, ERE, ERL, ECa, LRL, LRS, ETS, PFA, EPD, EPG
<b>Tunable White</b>	1 mixed PCB, with 2 BLS 12, amber from 1800 K to 4000 K
<b>Cut-off shield</b>	Medium or high as an option

\*Approx. 1800 K **E/L/P**: Illuminance/Luminance/Projection, **R/C/T/F/P**: Road/Circular/Pavement/Beam/  
Pedestrian crossing, **E/S/L/A/D/G**: Narrow/Standard/Wide/ Asymmetrical/Right/Left

### INSTALLATION

Removable battery cassette with locking screws  
The "panel + battery" assembly is rotatable through 360°  
(2 die-cast aluminium parts)

### WIRED

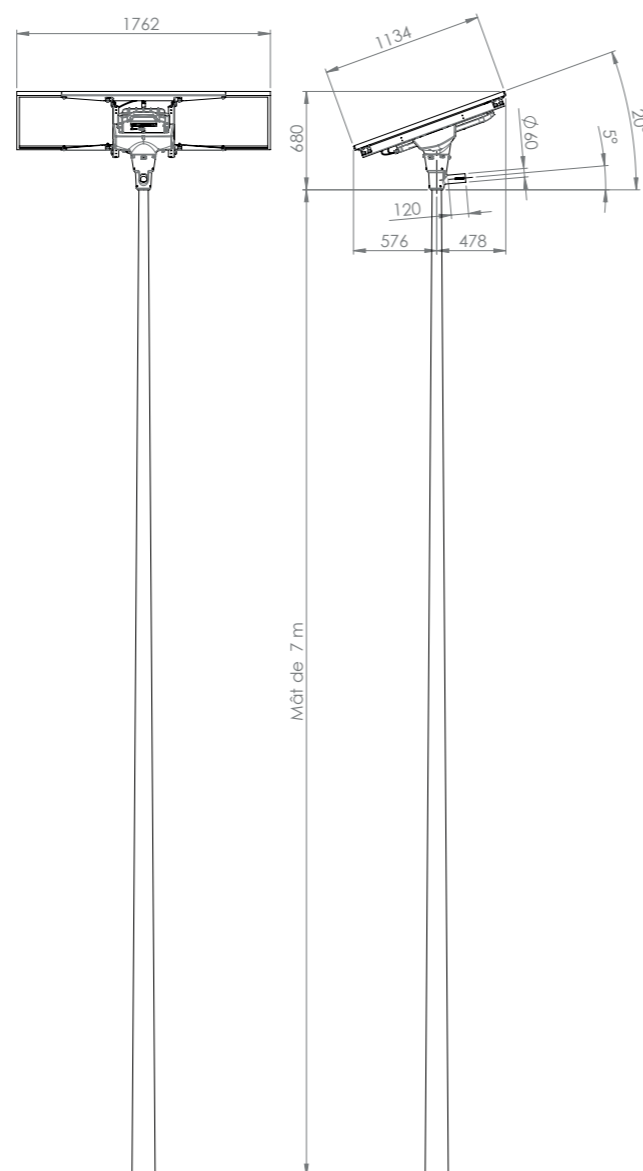

### DESCRIPTION

#### PHOTOVOLTAIC LIGHTING COLUMN FEATURING:

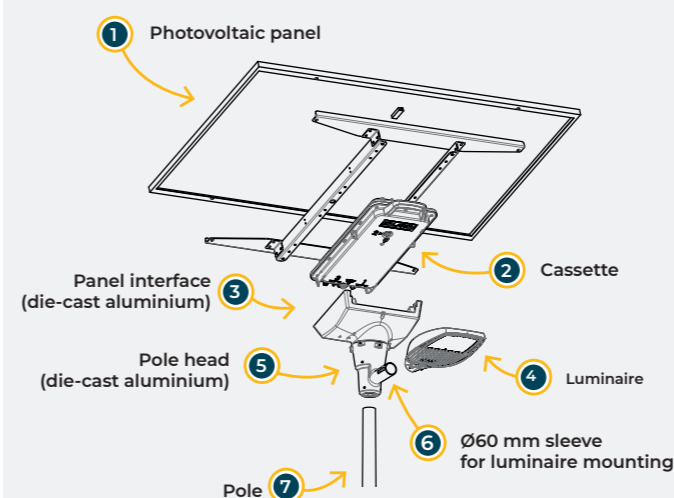

#### SUPPORT

<b>Pole</b>	Cylindrical-conical powder coated galvanised steel pole, without inspection hatch STRILUM option: Capitan or Helix design
<b>Height</b>	4 to 10 m
<b>Wind zone</b>	Zones 1 to 4 (22, 24, 26 and 28 m/s)
<b>Certification</b>	EN 40
<b>Base</b>	400 x 400 mm, centre-to-centre spacing 300 x 300 mm, J18 sealing
<b>Service life</b>	> 30 years
<b>Indicative block dimensions *</b>	4 m: 0.6 <sup>2</sup> x 0.8 m 5 m: 0.6 <sup>2</sup> x 0.9 m 6 m: 0.7 <sup>2</sup> x 1 m 7 m: 0.8 <sup>2</sup> x 1.1 m 8 m: 0.9 <sup>2</sup> x 1.1 m 9 m: 0.9 <sup>2</sup> x 1,1 m 10 m: 0.9 <sup>2</sup> x 1,2 m

\* These dimensions are given for information only and ECLATEC accepts no liability.  
The block and its reinforcements must be sized by a civil engineering design office.

#### MONOCRYSTALLINE PANEL

<b>Rated power</b>	440 Wc
<b>Efficiency</b>	22%
<b>Dimensions</b>	1762 x 1134 mm
<b>Surface area</b>	2 m <sup>2</sup>
<b>Tilt</b>	20°
<b>Orientation</b>	360°
<b>Service life</b>	> 25 years (85% of the rated power after 25 years)
<b>Recycling</b>	SOREN Organisation

#### BATTERY

<b>Technology</b>	Lithium Iron Phosphate. ECLATEC development
<b>Capacity</b>	F6: 614 Wh F12: 1228 Wh
<b>Location</b>	Removable cassette integrated into the rear of the panel
<b>Operating temperatures</b>	Discharge: -20 °C to +50 °C Charge: +0 °C to +45 °C
<b>Service life</b>	20 years (7000 cycles at 50% DoD/25°C)
<b>Recycling</b>	COREPILE Eco organisation

#### SMART BATTERY MANAGEMENT

<b>MPPT</b>	<b>MPPT ultra-fast charge controller</b> built into the cassette. It regulates the panel voltage and manages the panel current to optimise battery charging
<b>BMS module</b>	Electrical and thermal protection of the battery cells
<b>Service life</b>	MPPT: > 20 years



**SMART**  
 SUNPOLE C units have a range of programming and features for all uses, providing comfort and safety while protecting biodiversity.

1 SMART-READY PROVISIONS® ZD4™



Our luminaires can be fitted with the so-called "Smart-Ready®" provision, enabling plug-and-play interoperability via a standardised Zhaga interface and a power supply that meets D4i specifications.

Smart-Ready provisions® include a standardised Zhaga socket, on the top and/or the underside of the luminaire. These configurations are limited to 38W (2BLS12-500mA)

2 TUNABLE WHITE



3000 K Amber / 1800 K

The Tunable White solutions allow the luminaire's colour temperature to be varied at night to balance the needs of people and nature. They provide quality, comfortable and safe lighting for users, while taking into account the need to preserve biodiversity and limit light pollution.

All the night-time profiles and set-time configurations below are compatible with Tunable White solutions.

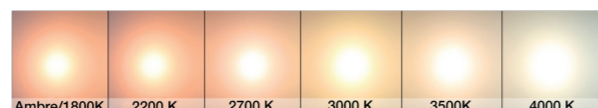

3 NIGHT-TIME DIMMING

The dimming functions make it possible to define up to 3 time slots with different powers depending on the ephemeris or at set times. A lights out slot can also be configured.

Dimming at set times

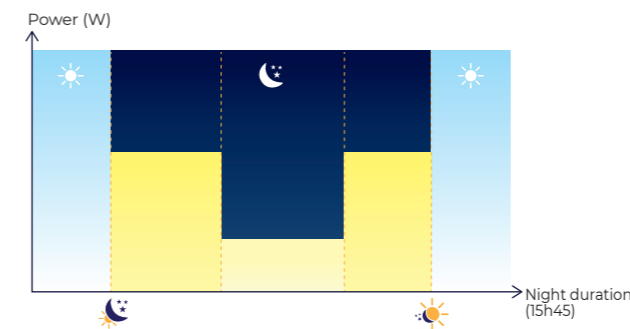

Dimming and lights out at set times

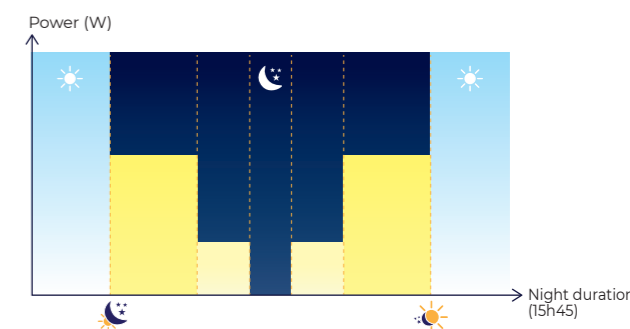

► Dimming with the option of partial or total lights out at set times throughout the year and/or according to the ephemeris.

4 DETECTIONS

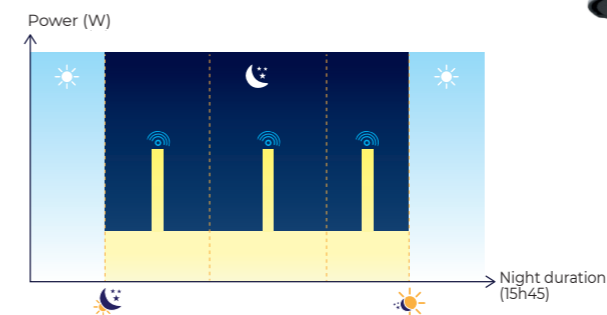

► Low level lighting or lights out when nothing is detected

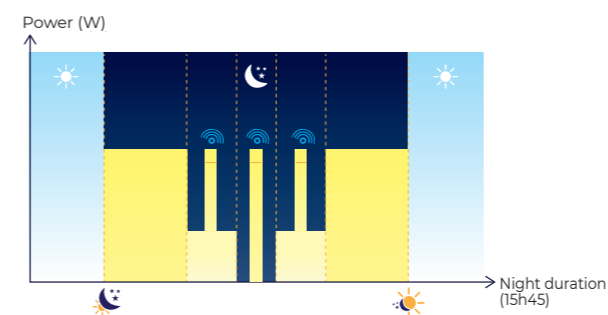

- Dimming with the option of partial or total lights out at set times throughout the year and/or according to the ephemeris.
- Adjustable high power level during detection
- Adjustable detector operating times



The PIR sensor built into the luminaire is used to switch the luminaire from a low power level, which can also correspond to lights out, to a high power level when pedestrians, cyclists or the like are detected at reduced speed.

The detection can also be coupled to night-time dimming.

5 FIXED POWER

The luminaire is switched on at the same power throughout the night, according to the ephemeris or at set times.

# SUNPOLE C



## Smart stand-alone lighting with WIZARD

### ► DYNAMIC LIGHTING

Communicating detection is used to increase the power of a group of luminaires when pedestrians, cyclists and the like are detected at moderate speed.

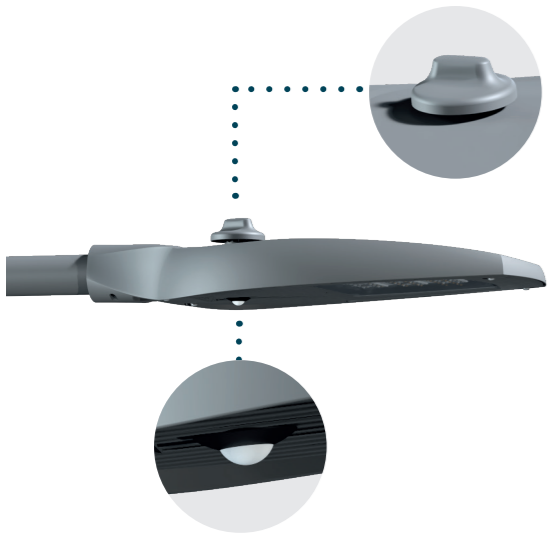

The luminaires communicate with each other via the ZigBee mesh radio protocol using Zhaga WIZARD antennas.

Different lighting configurations, dimming slots and power levels can be configured to provide optimum comfort comparable to a 'train of light', while optimising energy consumption.

### ► WIZARD REMOTE MANAGEMENT

WIZARD remote management is used to remotely manage all your solar lighting assets. This solution's two-way communication makes it possible to:

- Configure and control the lighting network in real time: lighting times, power levels, dynamic lighting, lights out, etc.
- Feedback on potential faults and, in particular, power consumption

The WIZARD remote management system uses open and standardised technologies. The luminaires fitted with a Zhaga WIZARD antenna communicate with each other and with a gateway using the ZigBee wireless protocol.

The gateway, which is the only element connected to the Internet using a SIM card, communicates with the Cloud using a secure web interface available on computers and tablets. The WIZARD application, available on tablets and iOS and Android smartphones, can be used to control installations and display information depending on user accreditation levels.

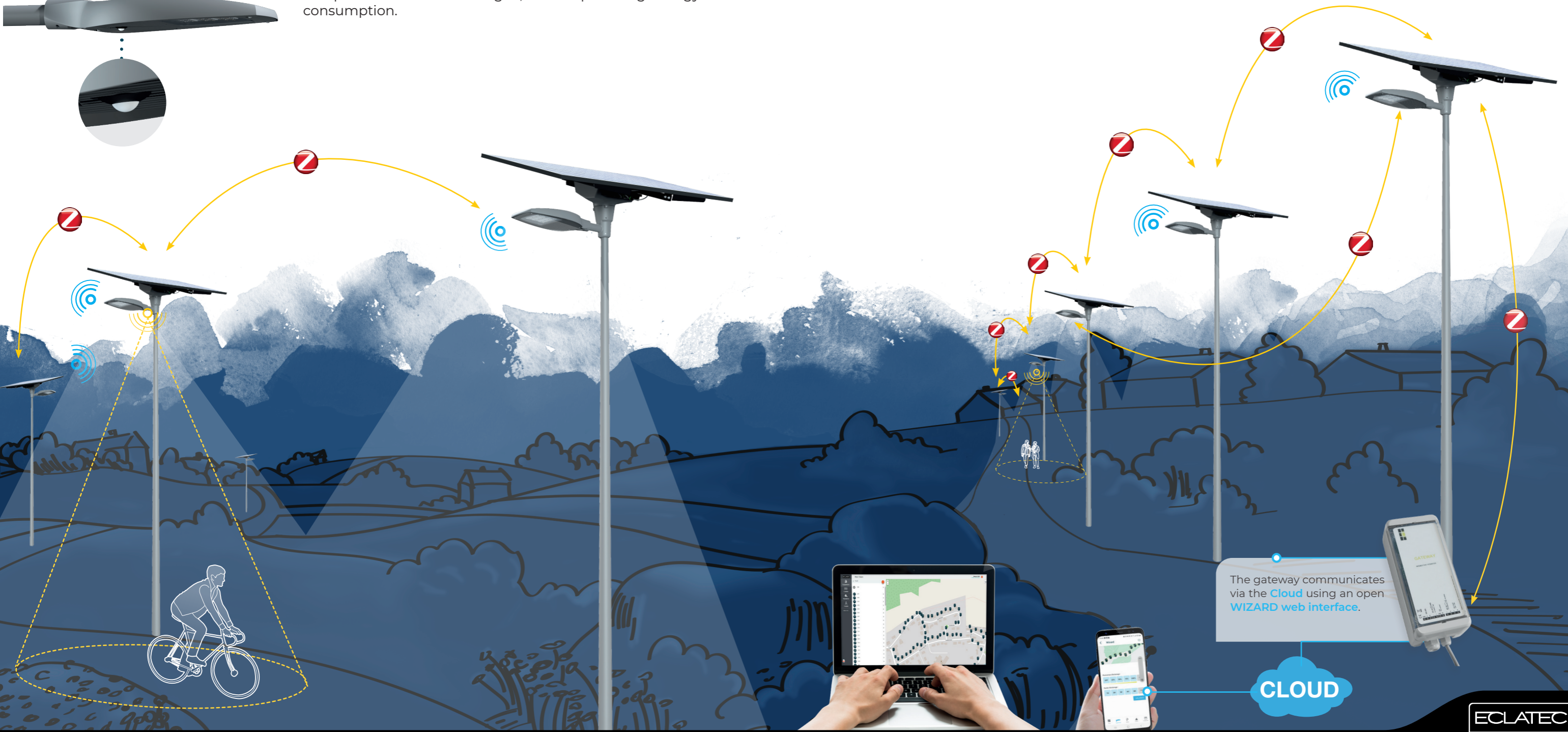

The gateway communicates via the **Cloud** using an open **WIZARD web interface**.



# PARKS & GARDENS, TRANSPORT & ACTIVE MOBILITY



# RESIDENTIAL AREA & TOWN CENTRE



**Configuration**  
Luminaire Pixel

**Configuration**  
Luminaire Beauregard  
Strium Capitan pole

**Configuration**  
Luminaire Teo

Strium designs available:  
Capitan Helix

6 m  
5 m  
4 m

# ROADS, CAR PARKS & TERTIARY

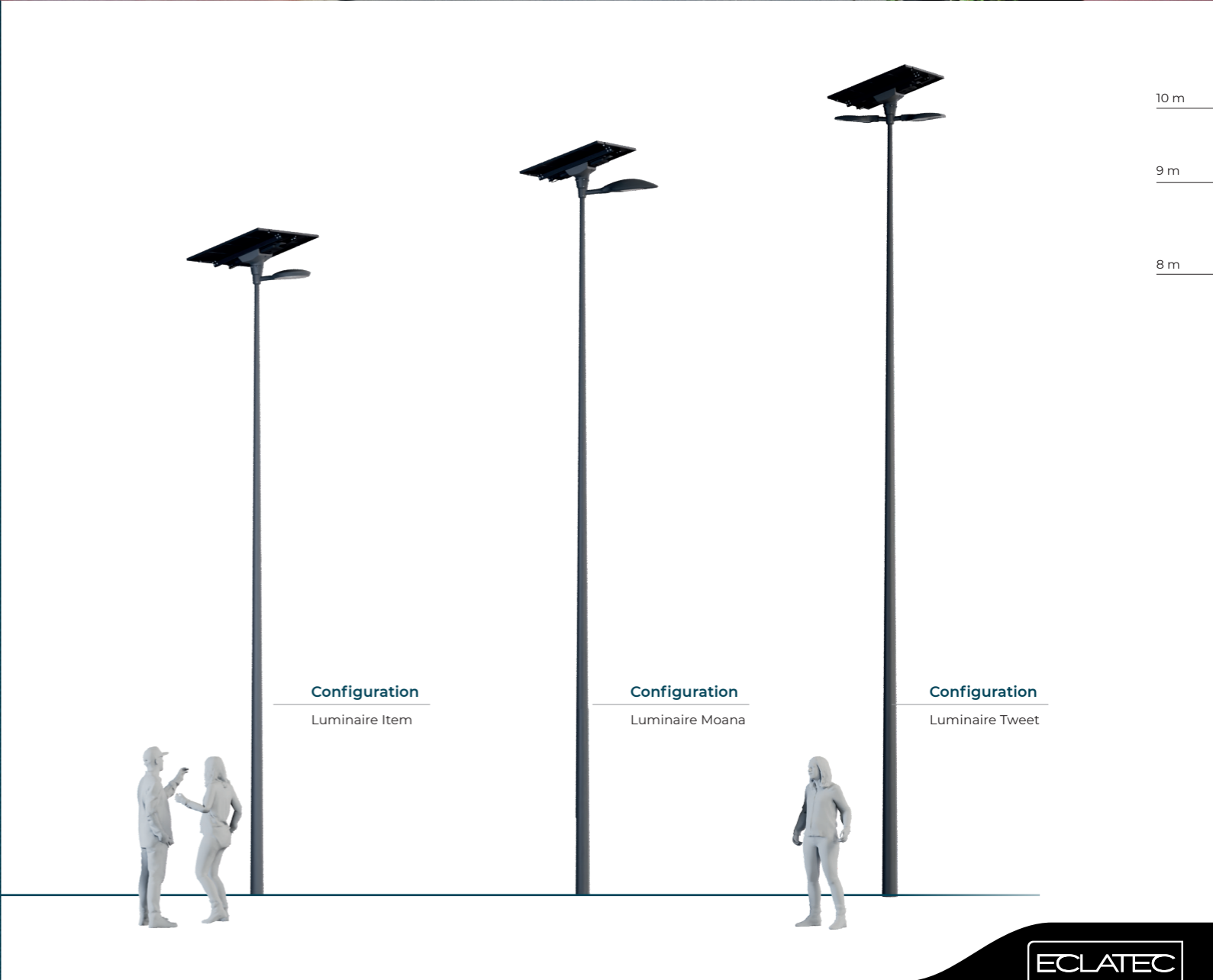

# POLE TILTING

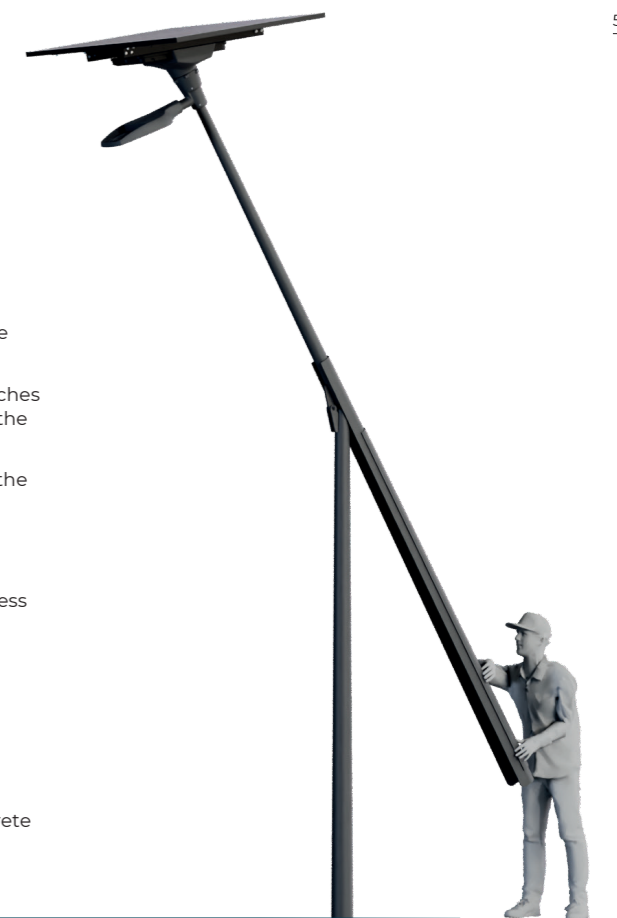
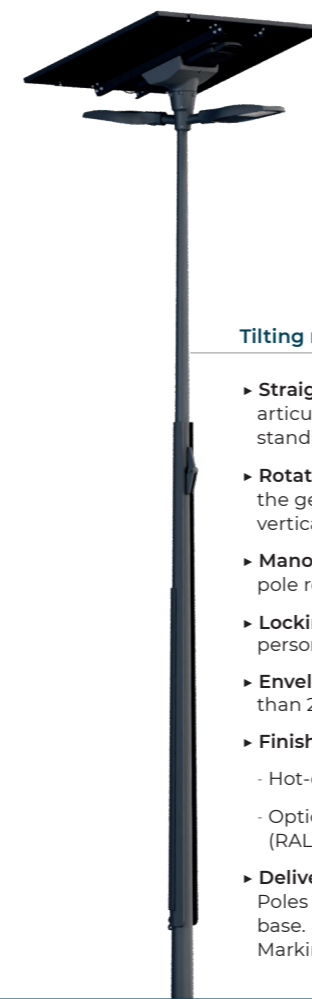

5.5 m

### Tilting mast

- ▶ **Straight 'cut' cylindrical-conical steel pole** 5 m with an articulated joint enabling access to the equipment while standing.
- ▶ **Rotating part fitted with an enveloping shell** that matches the geometry of the static part to limit visual impact in the vertical position.
- ▶ **Manoeuvring cable (with shackle included)** to control the pole rotation.
- ▶ **Locking system** restricting tilting access to authorised personnel.
- ▶ **Enveloping shell sized** to ensure an operating force of less than 20 kg.
- ▶ **Finish:**
  - Hot-dip galvanising as per the **NF EN ISO 1461**.
  - Optional: thermosetting polyester powder coating (RAL colour).
- ▶ **Delivery:** Poles assembled and ready to install on a suitable concrete base. Marking **CE** as per the **EN 40** standard.

# ECLATEC, A WINNING PARTNERSHIP!



## ECLATEC French leader in public lighting



ECLATEC is a **Designer-Manufacturer** of lighting solutions based in Nancy since 1927.

We offer a wide range of LED luminaires and smart solutions. Whether stand-alone or connected to a grid, they are designed to fulfil every photometric need.

Our values and technical expertise are at the service of your projects. We therefore define a lighting solution adapted to the uses and configuration of the surface areas to be lit.

“**Lighting properly**” is ECLATEC's permanent objective in the design of its lighting solutions.

### Because your project is unique

#### 1 Photometric requirements:

- ▶ Zone / surface area to be lit
- ▶ Compliance with applicable standards
- ▶ Definition of the appropriate power and photometric distribution

#### 2 Available solar energy:

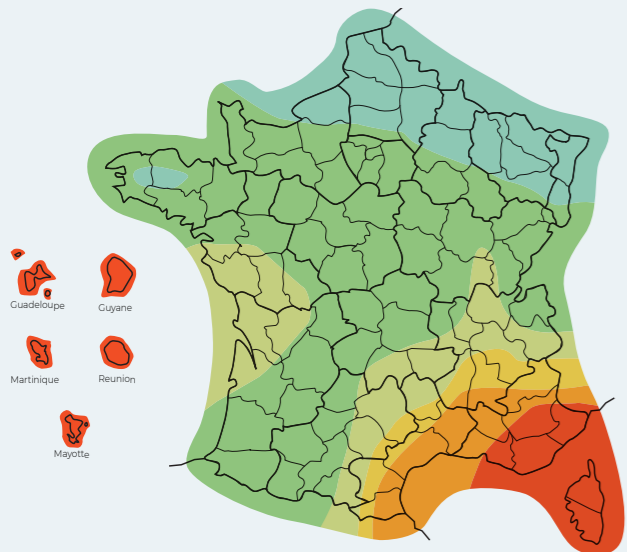

The amount of energy typically produced by panels varies depending on the region in which they are located.

#### 3 Following a study, your project sizing is implemented

### LIGHTING properly: what is needed, when it's needed, as much as necessary!

The intelligence embedded in our stand-alone solution is designed to provide continuity of lighting service while maximising lighting efficiency when necessary, thereby minimising light pollution and its impact on biodiversity.

#### For example:

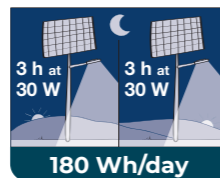

Constant 30 W lighting for 3 hours in the evening and 3 hours in the morning will require the following energy:  
 $30 \times (3+3) = 180 \text{ Wh/day}$

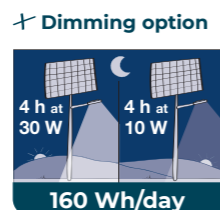

30 W lighting for 4 h and then 10 W for 4 h will require the following energy:  
 $(30 \times 4) + (10 \times 4) = 160 \text{ Wh/day}$

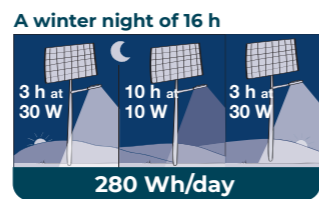

30 W lighting for 3 hours and then 10 W for 10 hours and 30 W for 3 hours, will require the following energy:  
 $(30 \times 3) + (10 \times 10) + (30 \times 3) = 280 \text{ Wh/day}$

### Responsible design

Drawing on its strong societal values, ECLATEC incorporates eco-design and circularity into its product development cycle.

Our research teams select high quality technical components for all our solutions.

Energy savings, compliance with standards and adapted lighting levels all require high quality equipment and solutions.

The careful study of their implementation conditions is an important source of energy optimisation: in every case, ECLATEC's Lighting Consultancy department recommends the best lighting solution, the best spacing, the best power or the best settings.

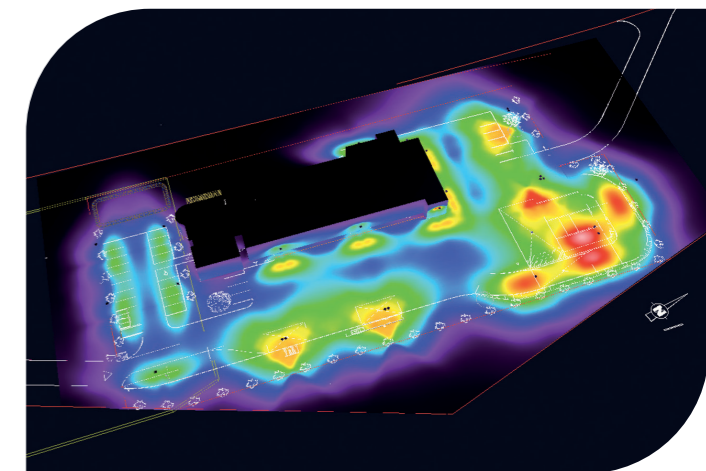

False colour rendering of a photometric study

### A personalised study

ECLATEC supports and advises decision-makers on their projects by following these 4 principles:

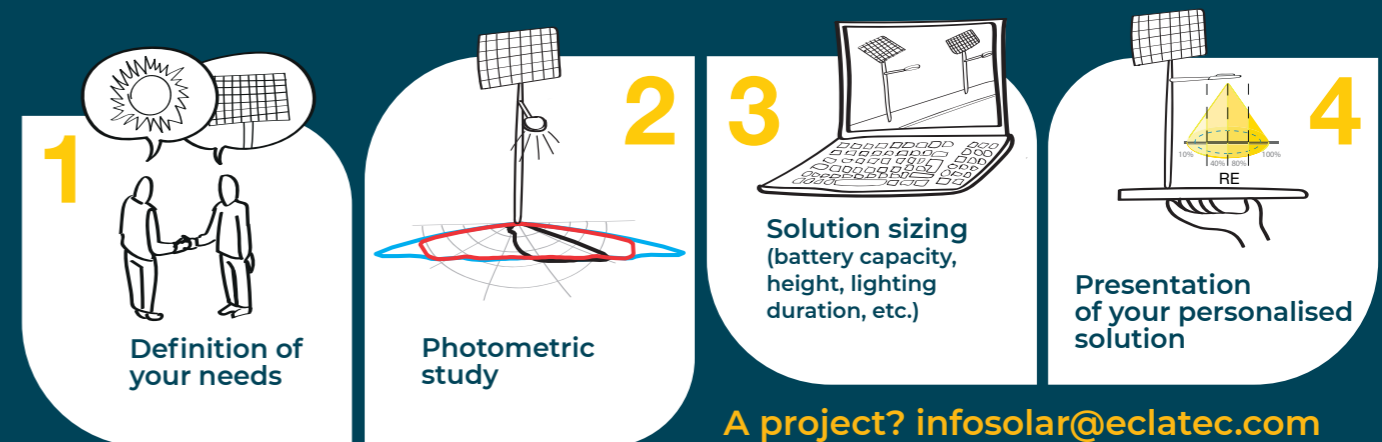

A project? [infosolar@eclatec.com](mailto:infosolar@eclatec.com)

# ECLATEC

41 rue Lafayette, CS 20069 Maxéville  
54528 Laxou cedex, France  
Phone: +33 (0)3 83 39 38 00  
[www.eclatec.com](http://www.eclatec.com)



ecosystem

Reproduction et diffusion interdites sans la permission écrite de ECLATEC - Copyright ECLATEC - Document and photographs are for information only. The description of the products and the dimensions given are for guidance only and cannot be construed as a contract. ECLATEC reserves the right to make any changes it deems necessary without prior notice. Service Clientèle: 03 83 39 38 00 - Photo: agence eclatec - © Stock

Edition  
09/2025